

APPROVAL DRAWING ALL DIMENSIONS MUST BE VERIFIED.

APPROVED
 APPROVED AS NOTED
 REVISE AND RESUBMIT

BY _____ DATE _____
 AUTHORIZED REP/ BUYER

ITEM NO.	QTY.	HEMCO PART NO.	DESCRIPTION
1	1	600101	WELDMENT, EXTENSION SUPPORT FRAME
2	1	600102	WELDMENT, EXTENSION RAMP
3	1	600103	WELDMENT, SUSPENSION POST RIGHT
4	1	600104	WELDMENT, SUSPENSION POST LEFT
5	1	600105	WELDMENT, FRONT POST LEFT
6	1	600106	WELDMENT, FRONT POST RIGHT
7	1	600107	WELDMENT, MID RAIL LEFT
8	2	600108	WELDMENT, TOP RAIL
9	1	600111	EXTENSION ARM
10	1	600120	WELDMENT, MID RAIL RIGHT
11	2	600062	SPRING CONNECTOR
12	2	600328	SPRING ASSY
13	2	700211	ROLLER ASSY, MAIN PLATFORM
14	1	800400	BASE MOUNT
15	1	100064	FRONT CONNECTING ROD
16	1	100622	PIVOT BAR
17	2	100785	TORSION ADJUSTABLE ROD ASSY
18	2	700210	ROLLER ASSY, EXTENSION PLATFORM
19	2	101044	PLATE, 1/4" THK, A36
20	2	101015	SUSPENSION BASE SPACER
21	1	600114	Gangway Safety Latch
22	2	101024	EXTENSION LINKAGE
23	2	100614	COLLAR, 1-1/4" SHAFT
24	2	100388	BEARING, MOUNTED SPHERICAL, 3/4"
25	2	100527	BEARING, 2 BOLT FLANGE
26	4	100746	SAE BRONZE SLEEVE MMC 2938T25
27	2	100793	NUT, HEX, SLOTTED, 1"-8 UNC
28	2	100054	PIN, COTTER, 1/4" X 1-1/4" LG
29	2	100495	PULL CHAIN
30	2	600110	SPRING COVER

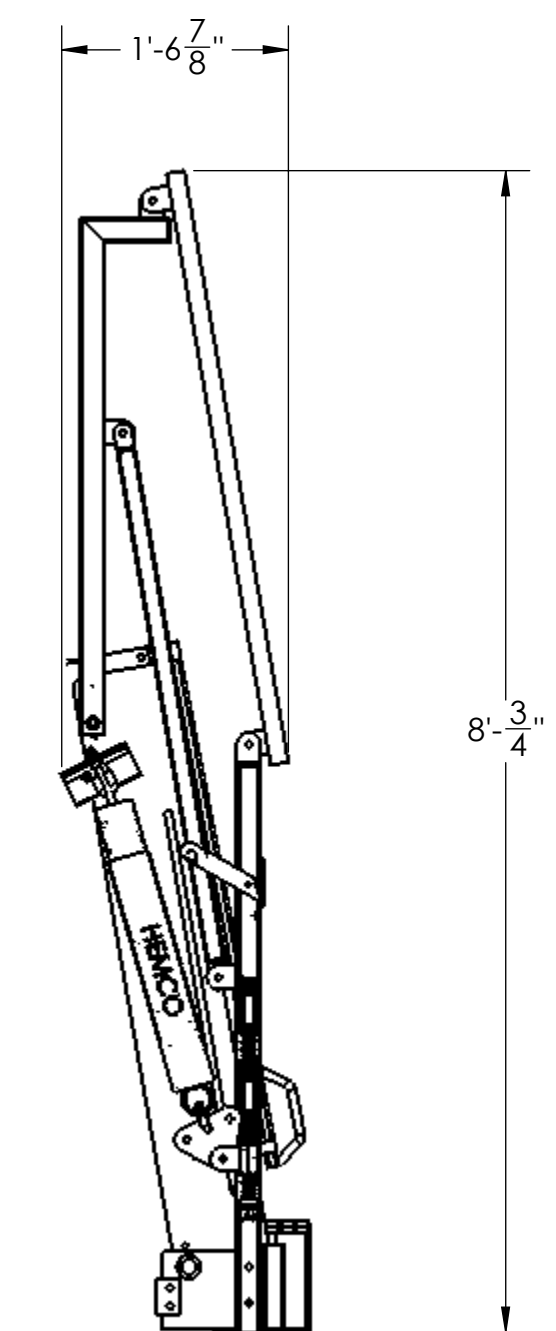
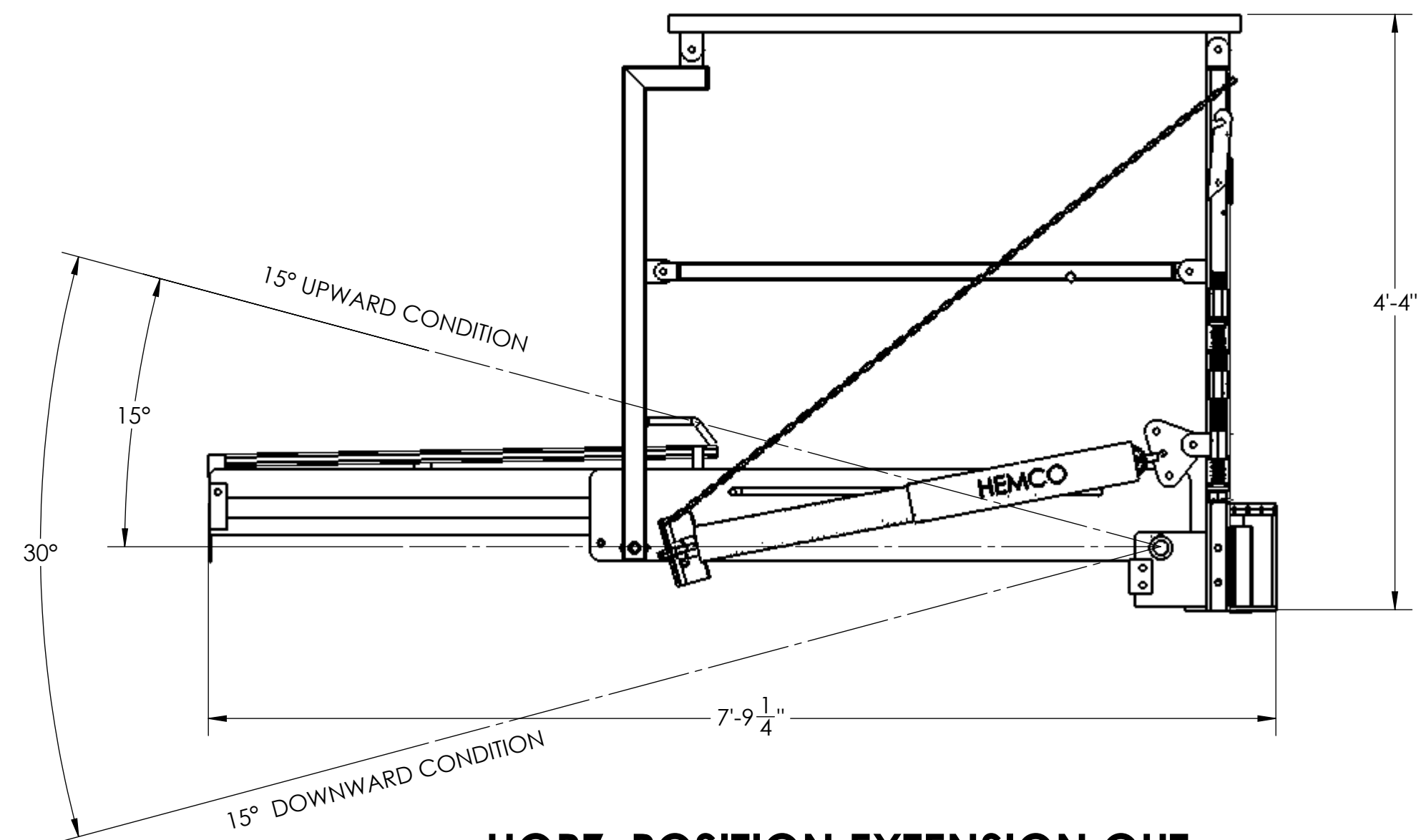
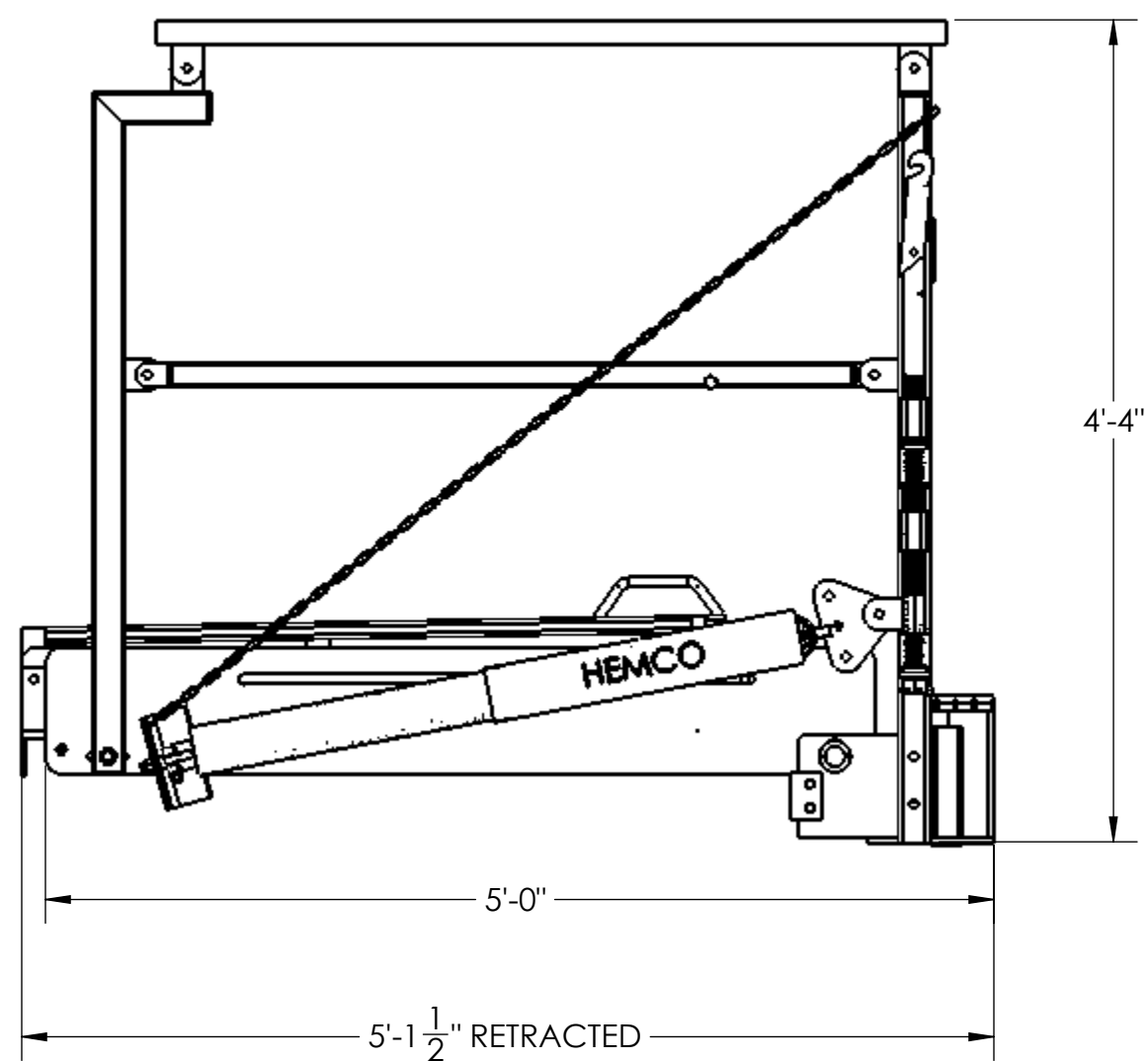

HORZ. POSITION EXTENSION IN

HORZ. POSITION EXTENSION OUT

STORED POSITION

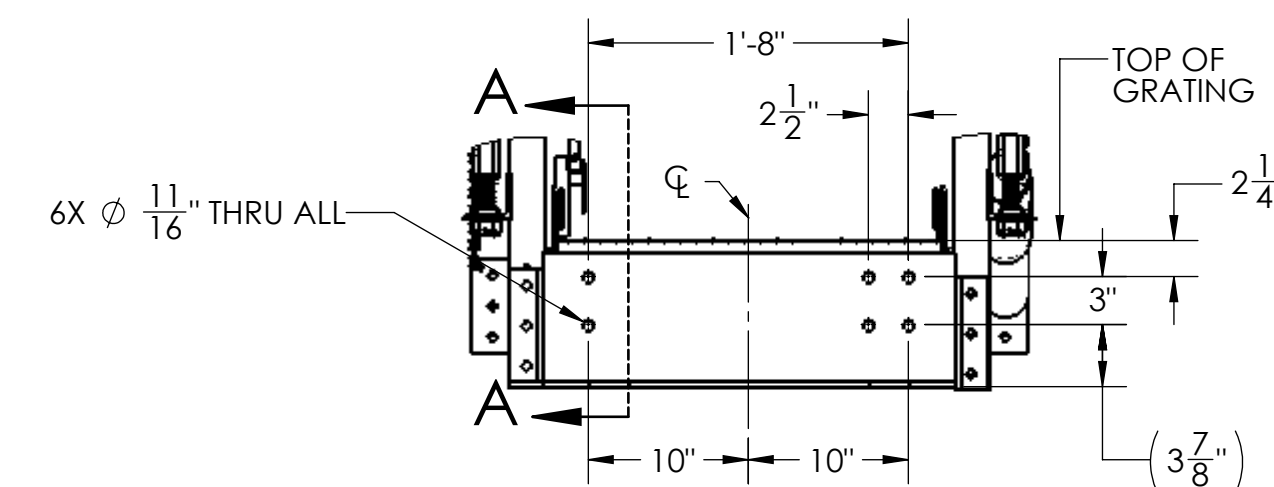

MOUNTING BOLT PATTERN

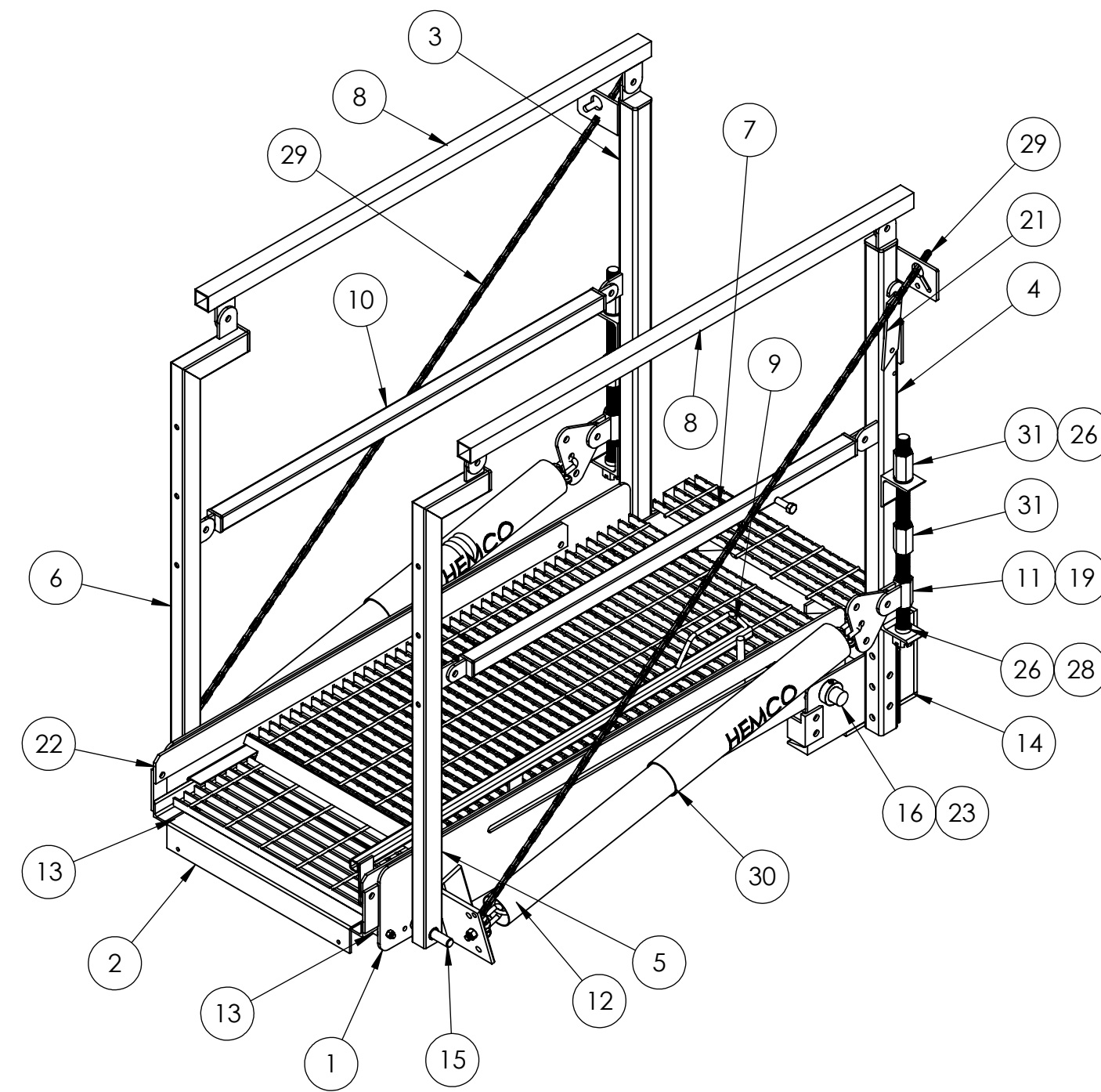
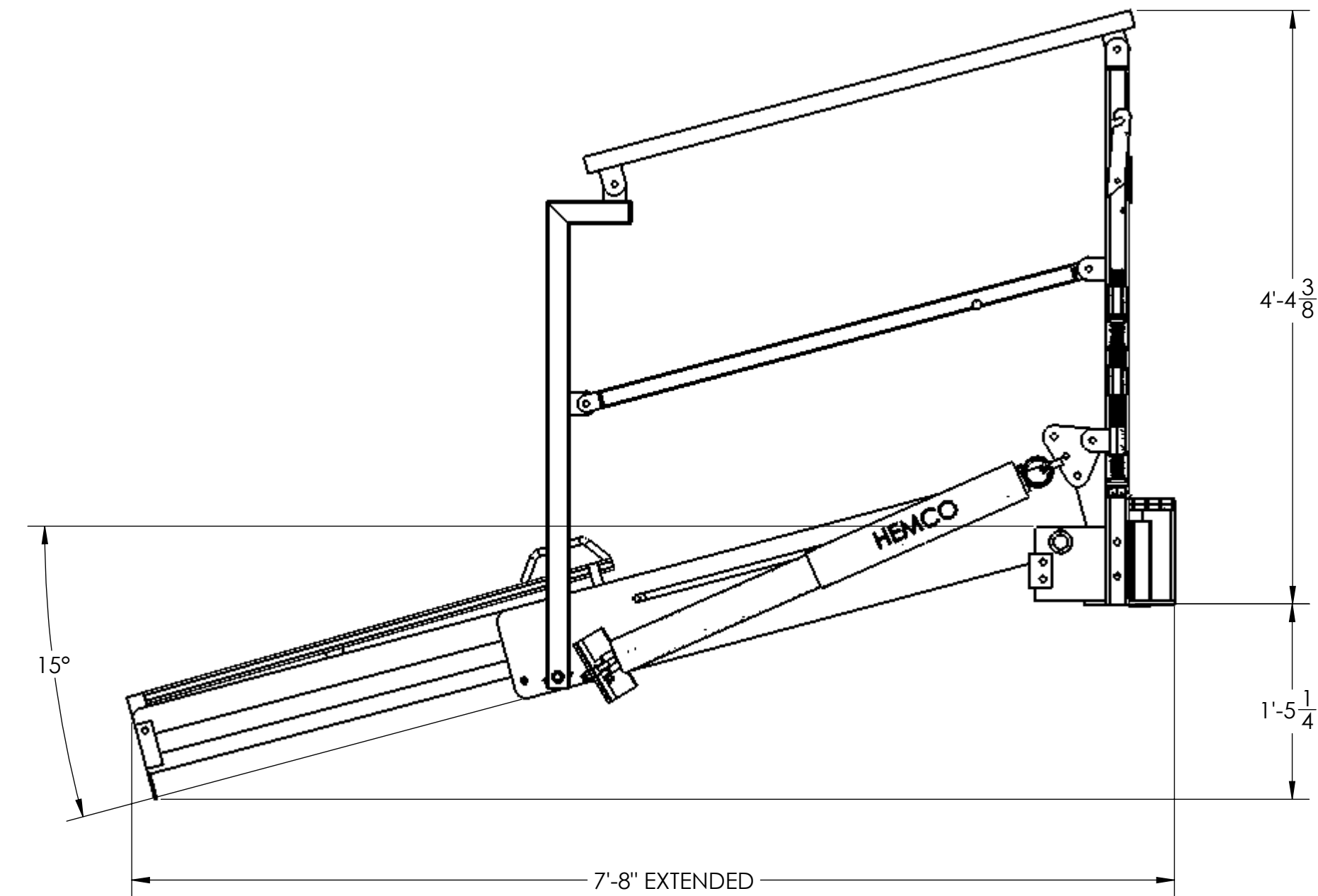
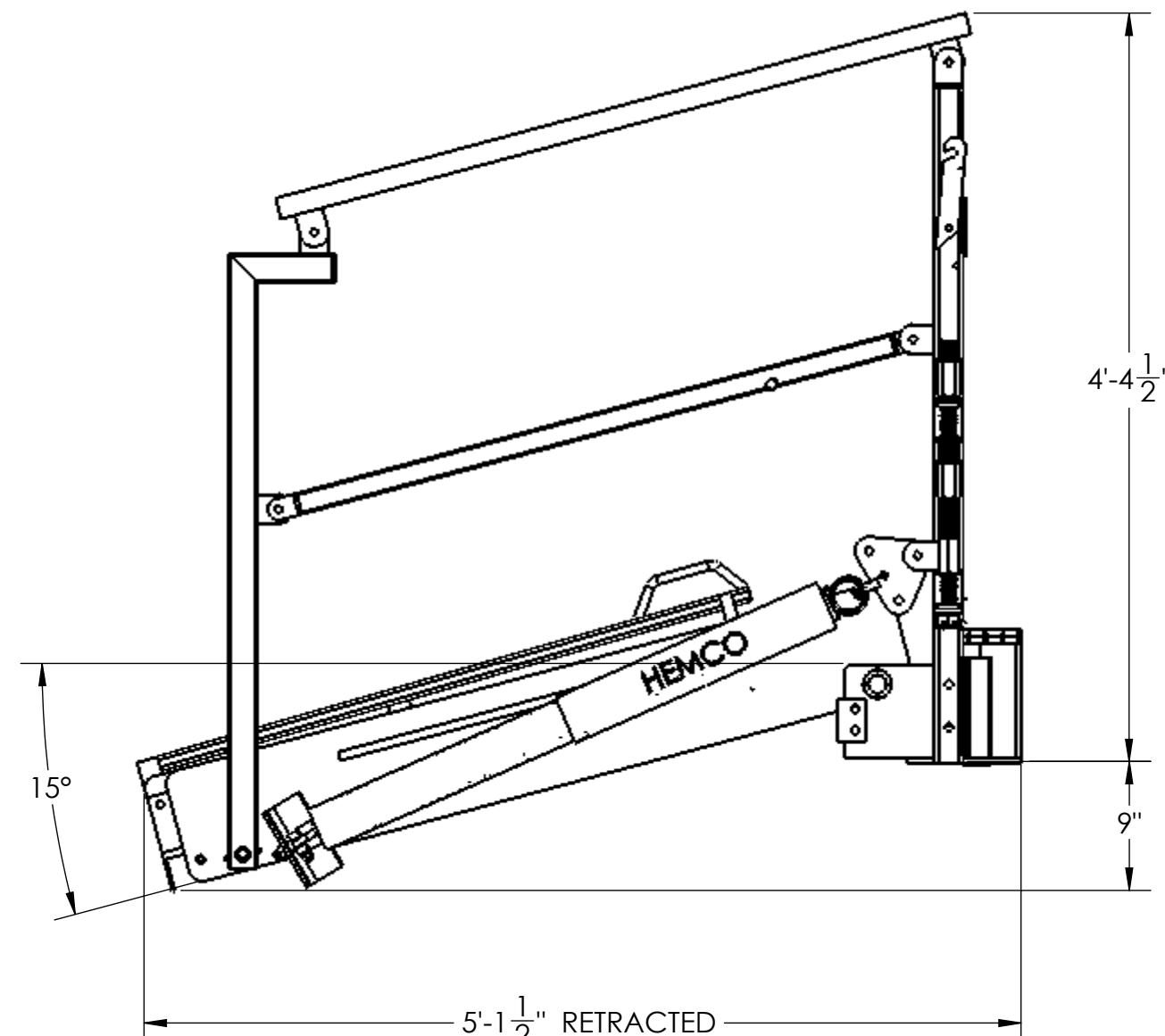

ISO VIEW

15° DECLINE EXTENSION IN

15° DECLINE EXTENSION OUTWARD

SECTION A-A

UNLESS OTHERWISE SPECIFIED:
 DIMENSIONS ARE IN INCHES
 TOLERANCES:
 FRACTIONAL ±
 ANGULAR MATCH ± BEND ±
 TWO PLACE DECIMAL ±
 THREE PLACE DECIMAL ±

INTERPRET GEOMETRIC TOLERANCING PER:
 MATERIAL:
 SEE BOM

DO NOT SCALE DRAWING

NAME	DATE	2488 Kartach St. Houston, Texas 77092 (713)881-2426 www.hemcoind.com
DRAWN	5/03	03-20-15
CHECKED		
ENG APPR:		
MFG APPR:		
G.A.		

PROPRIETARY AND CONFIDENTIAL
 THE INFORMATION CONTAINED IN THIS DRAWING IS THE SOLE PROPERTY OF HEMCO INC. ANY REPRODUCTION IN PART OR AS A WHOLE WITHOUT THE WRITTEN PERMISSION OF HEMCO INC. IS PROHIBITED.

REV.	DESCRIPTION	DATE	REV. BY
REVISIONS			

SCALE: NTS WEIGHT: 500 LBS SHEET 1 OF 1

Hemco
 TITAN-24 GC GANGWAY
 DWG. NO. 910006
 REV B

D 910006